

Product Technical Data sheet

The Block Shop NZ Ltd concrete kerb block range is produced with high quality graded pumice and sand, utilising top grade NZ sourced cement and additives.

Straight, Drive Over & Radius Kerb blocks are produced.

Please refer to your local authority for installation details and requirements.

Technical Data

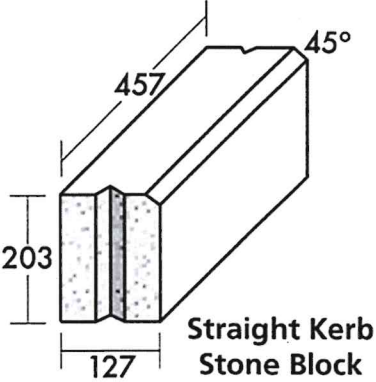
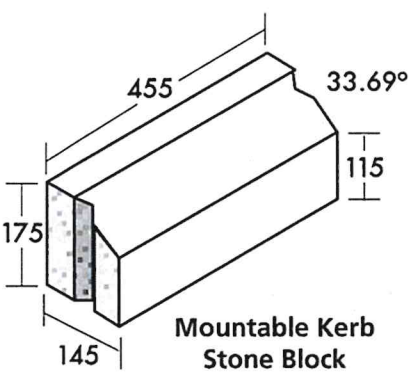
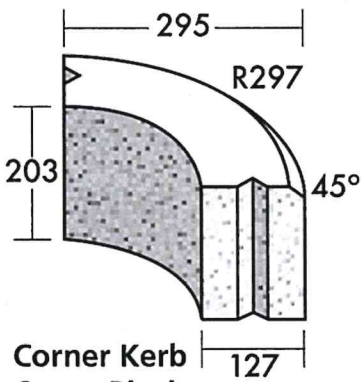
Colour	Grey			
Block Weight	Std block when Dry	Typically less than	24 Kg	Standard block
	Std block when Dry	Typically less than	23 kg	Drive Over Block
	Std block when Dry	Typically less than	19kg	Radius Block
Unconfined Compressive Strength	AS/NZS3112.3	Core Drill Test Method	20MPa	Conforms with Auckland Transport TDM Technical Data Standards
Work size tolerances	Tested to NZS 4456.3;2003	Internally tested.	Max deviation 150-250mm +/- 90mm cumulative over 20 units in accordance with NZS 4455.1:2008 2.2.3	
 <p>Straight Kerb Stone Block 2.2 per Lineal Metre</p>		 <p>Mountable Kerb Stone Block 2.2 per Lineal Metre</p>		 <p>Corner Kerb Stone Block</p>

Health and Safety

Avoid breathing dust when cutting or grinding as dust contains Silica and cement particles.
 Wear a paper dust mask during such operations.

Dave Shortt
Director